

SMA2 Spring Mount (Deflection : 50mm)

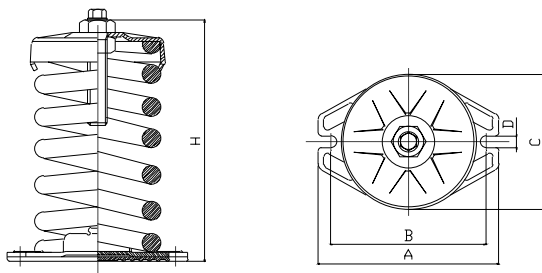
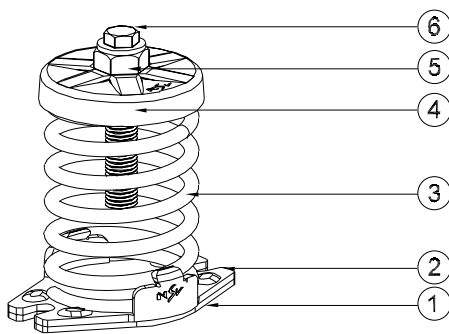

■ Features

As an open spring mount, it is usually used together with the inertia base. It is easy to install and has a static deflection that is visible to the naked eye, which facilitates inspection after installation. It has the same components as SMA type, but has a static deflection of 50 mm, and therefore, it is used when operation of equipment needs to be quieter, such as when air conditioners and fans and are installed on the ground level within the building. The top cap is made of SS400 steel plate, and it can be welded to the bottom structure, when it is made of steel, like the H beam, without making an extra hole for installation. There is a CR type pad attached on the base plate for a slip resistant and high frequency isolation.

■ Usage

- ◆ For standing pipes
- ◆ For high-efficient vibration control of ventilators (ground level)
- ◆ For high-efficient vibration control of air conditioning units (ground level)
- ◆ For high-efficient vibration control of equipment that needs to be kept quiet

■ Specification

No.	Name of Components	Material	Standard
1	Non Skid Pad	CR	KS M 6617
2	Lower Housing	SS400	KS D 3503
3	Coil Spring	SUP9	KS B 2402
		HSW3	KS B 2403
4	Upper Spring Cap	SS400	KS D 3503
5	Level Bolt	SS400	KS B 1002
6	Cap Screw	SS400	KS B 1002

■ Dimension & Selection Guide

Type	Capacity (kgf)	Spring Constant (kgf/mm)	Weight (kg)	Color	Dimension(mm)						
					A	B	C	D	H	Level Bolt	Cap Screw
SMA2-A-100	100	2	2.00	Blue	150	123	106	14	170	M20 x 90	M12 x 25
SMA2-A-150	150	3	2.00	Brown							
SMA2-A-200	200	4	2.04	White							
SMA2-A-300	300	6	2.18	Orange							
SMA2-A-400	400	8	2.46	Pink							
SMA2-A-500	500	10	2.78	Green							
SMA2-A-600	600	12	3.34	Blue							
SMA2-A-750	750	15	3.08	Black							
SMA2-A-1000	1000	20	3.38	Yellow							
SMA2-B-1200	1200	24	7.60	Red							
SMA2-B-1500	1500	30	7.62	Black							
SMA2-B-1800	1800	36	7.12	Blue							
SMA2-B-2000	2000	40	8.90	Yellow							
SMA2-B-2500	2500	50	11.60	Brown							
SMA2-C-3000	3000	60	12.60	White	214	184	160	14	289	M24 x 110	M12 x 25
SMA2-C-3500	3500	70	13.40	Black							
SMA2-C-4000	4000	80	13.40	Orange							

(NOTE) The mentioned size and scale can be altered to improve the quality performance and capacity of the product without any notice.

SMA2 Spring Mount (Deflection : 50mm)

■ SMA2 Test Data

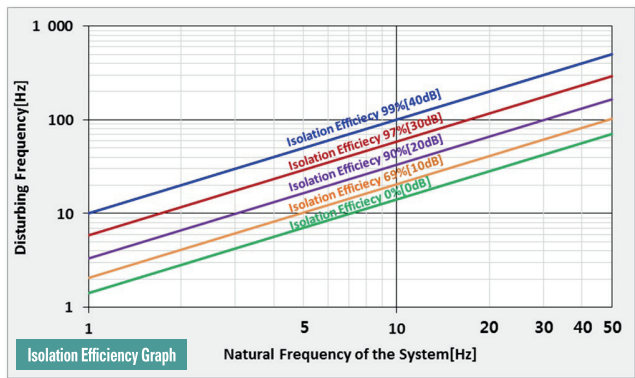
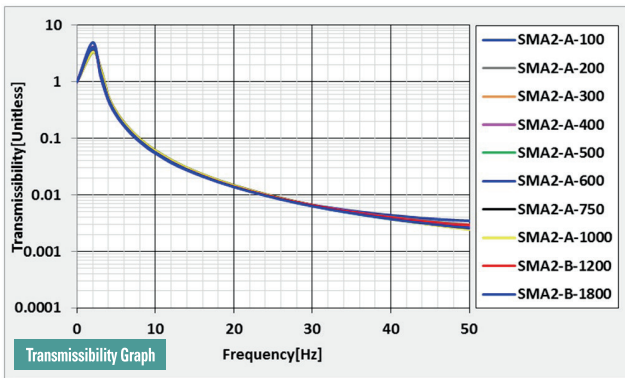
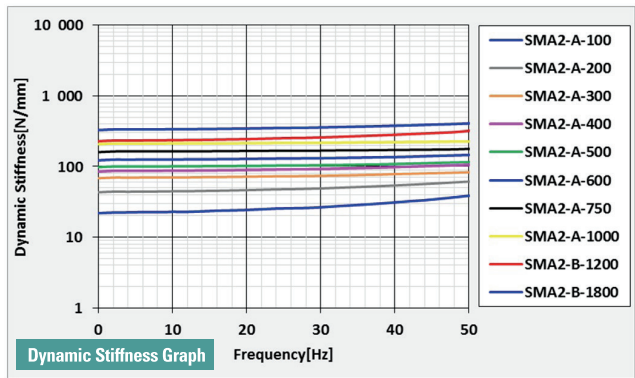
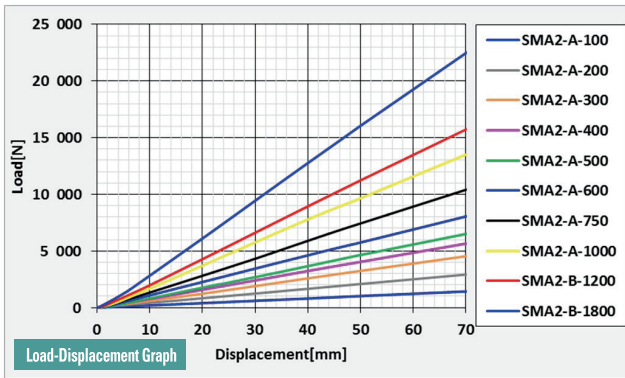

■ Installation Features

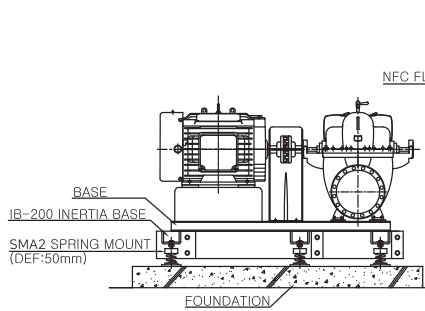

DOUBLE SUCTION PUMP DETAIL

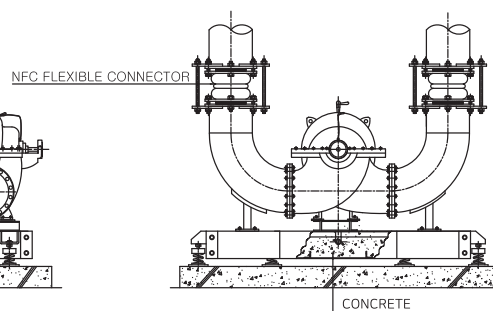

SPRING MOUNT INSTALL DETAIL

